



Development of Electric Powertrain for CLARITY PLUG-IN HYBRID

Tomoya Yamagishi and Takashi Ishikura Honda R&D Co., Ltd.

Citation: Yamagishi, T. and Ishikura, T., "Development of Electric Powertrain for CLARITY PLUG-IN HYBRID," SAE Technical Paper 2018-01-0415, 2018, doi:10.4271/2018-01-0415.

Abstract

Honda has developed the 2017 model CLARITY PLUG-IN HYBRID. Honda's new plug-in hybrid is a midsize sedan, and shares a body platform with the CLARITY FUEL CELL and the CLARITY ELECTRIC. The vehicle's electric powertrain boosts driving performance as an electric vehicle over Honda's previous plug-in hybrid.

The CLARITY PLUG-IN HYBRID's electric powertrain consists of a traction motor and generator built into the transmission, a Power Control Unit positioned above the transmission, an Intelligent Power Unit fitted under the floor, and an Onboard Charger fitted below the rear trunk.

The Power Control Unit integrates an inverter that drives the traction motor, an inverter that drives the generator, and a DC-DC converter to boost battery voltage (referred to as a "Voltage Control Unit (VCU)" below). The VCU employs an interleaved circuit configuration and a coupled inductor, and realizes approximately three times the rated continuous power and approximately three times the power density of a standard unit employed in a hybrid vehicle.

The Intelligent Power Unit contains 17 kWh high-capacity battery modules and a 12 V DC-DC converter. A coolant-cooling method has been adopted to respond to the increased power of the battery, boosting cooling performance. The battery modules are positioned below the front and rear seats, and the high-voltage wiring is positioned between the modules, in the center of the vehicle. This layout has made it possible to fit the Intelligent Power Unit below the floor of the vehicle, helping to enable the realization of a spacious and comfortable cabin seating five passengers, as well as a useful amount of trunk space.

The use of a high-power Voltage Control Unit and a high-capacity Intelligent Power Unit has made it possible to realize EV operation in the high-speed range with no need to start the engine, giving the vehicle an adequate all-electric range for everyday use. During hybrid operation, increasing both the VCU power and the battery power helps ensure quietness while also allows the engine to be downsized from 2.0 to 1.5 liters. The developed electric powertrain realizes a long all-electric range (AER) of 47 miles, and extremely quiet hybrid operation with a high level of fuel economy at 42 mpg.

Introduction

Today, the development and popularization of environmentally-conscious vehicles is essential as a response to global warming, air pollution, and energy issues. Honda has now developed three vehicles in its CLARITY series employing three different power-plants in a shared body platform: The CLARITY FUEL CELL, a fuel cell vehicle, the CLARITY ELECTRIC, an electric vehicle (EV), and the CLARITY PLUG-IN HYBRID, a plug-in hybrid electric vehicle (PHEV).

Honda's CLARITY PLUG-IN HYBRID features a higher-capacity battery, which extends the vehicle's all-electric range (AER) to 47 miles. Increased battery and VCU power have made it possible to extend engine-free EV operation across the entire vehicle speed range, realizing a maximum speed of 100 mph. As a result, the majority of everyday driving can be conducted using the vehicle as an EV. The expansion of the

range of EV operation offers users the smooth acceleration and quietness that are characteristic of EV. During hybrid operation, the vehicle realizes a high 42 mpg level of fuel economy, and is capable of long-distance driving. This means that the majority of everyday driving (commuting to work or school, etc.) can be conducted as an EV, while longer distances (weekend trips, etc.) can be covered using the vehicle as a hybrid, with the engine generating power. As an electric vehicle able to offer a greater number of users the unique appeal of EV driving together with a sufficient range, the CLARITY PLUG-IN HYBRID can be expected to contribute to the popularization of environmentally-conscious vehicles in the future.

This paper will discuss the features of the powertrain system and the newly developed Power Control Unit (PCU) and Intelligent Power Unit (IPU) employed in the CLARITY PLUG-IN HYBRID.

Overview of Powertrain System

Powertrain Layout and Specifications

Figure 1 shows the powertrain layout in the vehicle. The drive motor, generator, engine and PCU are positioned in the engine room at the front of the vehicle, while the IPU is positioned under the floor. An On Board Charger for charging the battery is fitted to the rear sub-frame.

Figure 2 shows a side view of the powertrain layout. The under-floor positioning of the IPU has made it possible to realize a spacious cabin seating five passengers, while also allowing the fitting of the high-capacity battery. In addition, because there is no need to fit the battery in the trunk, the layout also helps to realize a spacious trunk.

Table 1 shows the specifications of the vehicle and individual components.

Overview of Vehicle and Powertrain Operation

Figure 3 shows an image of PHEV operation and the battery state of charge (SOC). The vehicle operates as an EV when there is a high SOC following charging of the battery. (When power

TABLE 1 Vehicle and powertrain specifications

Model		CLARITY PLUG-IN HYBRID	Previous PHEV
Vehicle	Length/Width/Height	4895 mm/1875 mm/1475 mm	4910 mm/1850 mm/1465 mm
	Wheel base	2750 mm	2775 mm
	Vehicle weight	1843 kg	1730 kg
	Number of passengers	5	5
	All electric range(EPA)	47 miles	13 miles
	Fuel economy(EPA) (combined)	CD 110MPGe CS 42MPG	CD 115MPGe CS 46MPG
	Engine	Type	L4 1.5 L port injection Atkinson cycle
Engine	Power	76.5 kW	105 kW
	Torque	134 Nm	165 Nm
Traction motor	Type	DC brushless motor	DC brushless motor
	Power	135 kW	124 kW
	Torque	315 Nm	307 Nm
Battery	Type	Li-ion	Li-ion
	Capacity	17.0kWh	6.7kWh
PCU	Maximum output (Motor inverter)	360kVA	400kVA
	Maximum voltage	650 V	700 V
	VCU maximum output	(1.3-fold) kW (In comparison with previous PHEV)	(Undisclosed)
	VCU continuous power	(3.3-fold) kW (In comparison with previous PHEV)	(Undisclosed)
Charger	Output (at AC240 V)	6.6 kW	6.6 kW

© SAE International

FIGURE 1 Powertrain layout

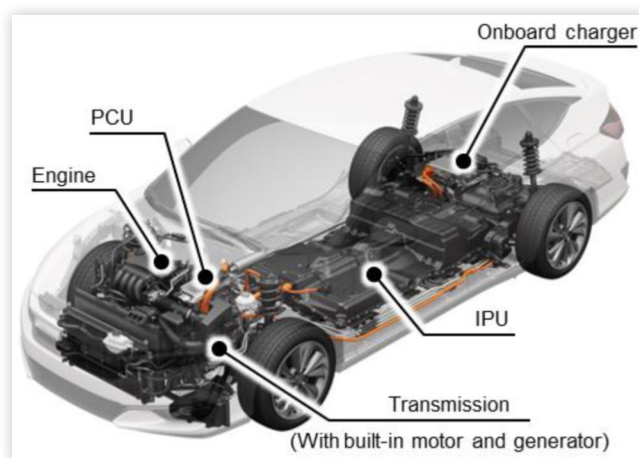

© SAE International

FIGURE 2 Side view of powertrain layout

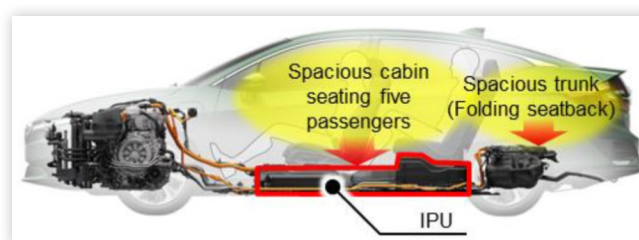

© SAE International

FIGURE 3 Image of vehicle operation

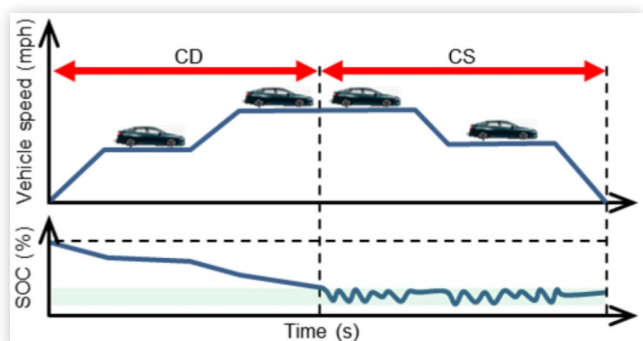

© SAE International

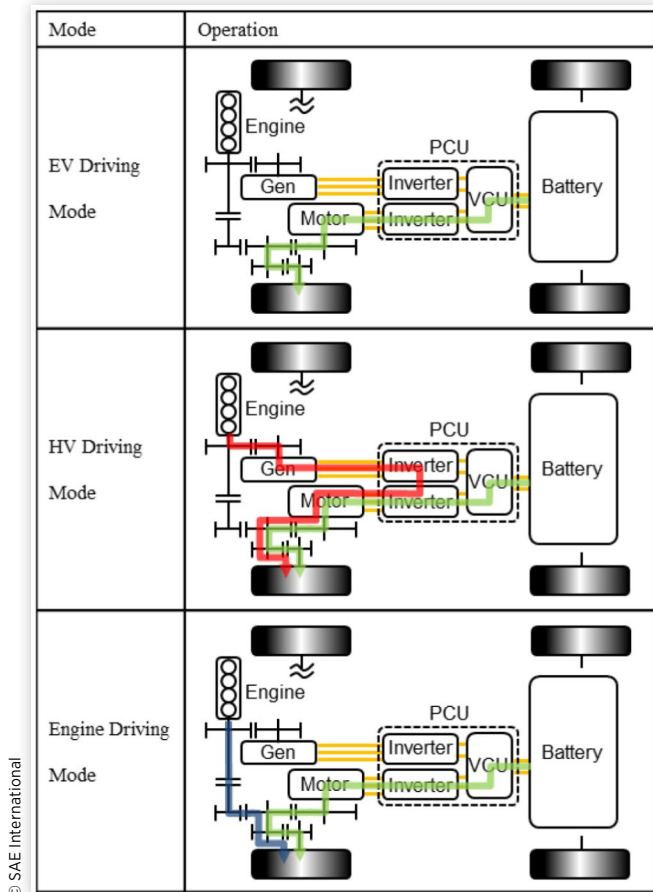
FIGURE 4 Powertrain operation

is demanded that exceeds the range for EV operation, the engine is also used.) When the SOC declines as a result of charge-depleting (CD) operation, the system makes the transition to charge-sustaining (CS) operation, in which the engine is also used. During CS operation, the powertrain operates to maintain the SOC by means of power generation by the engine.

Figure 4 shows the configuration of the powertrain and its driving modes. The power-plant is made up of a motor, for vehicle operation and power regeneration, a generator, for generating power and starting the engine, an engine, a battery, and a PCU. The PCU integrates an inverter that drives the motor, an inverter that drives the generator, and a DC-DC converter that boosts battery voltage (VCU). The engine is directly connected to the generator, and is connected to an axle shaft via the clutch.

The system's driving modes are EV Driving Mode, in which the motor is driven by battery power, HV Driving Mode, in which both engine generated power and battery power are used, and Engine Driving Mode, in which both engine power (via the connection to the clutch) and motor power are used.

Maximum Speed and AER as EV

During EV Driving Mode, as shown in Figure 4, the motor is driven exclusively by power from the battery. When the

vehicle is driving at high speeds or is operating under a high load, such as when climbing a hill, the VCU boosts the battery voltage in order to drive the motor. The motor drive voltage is controlled by the VCU in order to realize the demanded power while maintaining overall efficiency at the optimum level.

Figure 5 shows the AER at each vehicle speed and maximum speed during EV operation with a fully charged battery. The capacity of the battery in the developed vehicle has been increased to 17 kWh, increasing the vehicle's AER approximately 3.6-fold. Increased power in the battery and VCU has made it possible to realize a maximum speed of 100 mph during EV operation.

Figure 6 shows the proportion of weekday US user driving distance. The capacity of the CLARITY's battery was set at 17 kWh to realize an AER of 47 miles, representing approximately 80% of weekday US user driving distance.

This AER and speed range during EV operation make it possible for the vehicle to be used as an EV for weekday driving by the majority of users.

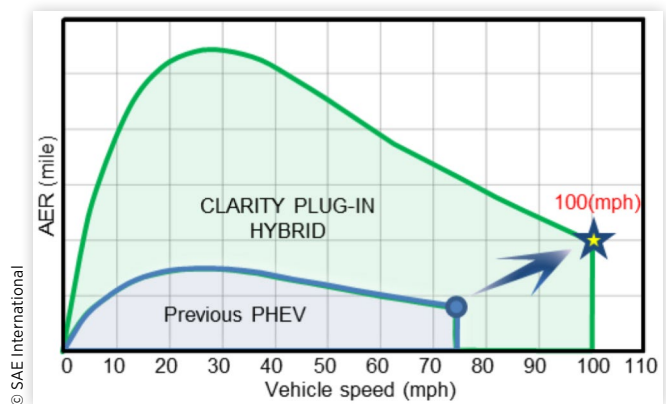
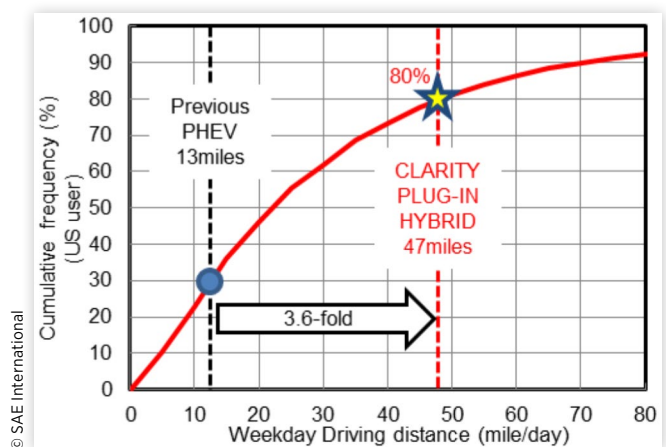
FIGURE 5 AER at each vehicle speed and maximum speed during EV operation**FIGURE 6** Proportion of weekday US user driving distance (Original survey by Honda)

Power-Plant Operation and Engine Downsizing

Figure 7 shows the system operation at each vehicle speed and motor torque. When power is demanded that exceeds the range for EV operation, the system operates in HV Driving Mode or Engine Driving Mode. When the demand for power declines, the system returns to EV operation.

During CS operation, the range for EV operation is reduced in response to the decline in the battery SOC, and the system operates to maintain the battery SOC by means of series generation by the engine. HV Driving Mode or Engine Driving Mode is selected in order to help ensure optimal total powertrain efficiency.

During both CD and CS operation, battery power is the main source of the demanded drive power in the high-load range, with the shortfall being supplemented through generation by the engine.

The increased battery and VCU power realized in this system has expanded the range for EV power against the previous PHEV. Engine power has been reduced while increasing the motor power, making it possible to downsize the engine from 2.0 to 1.5 L.

Figure 8 shows the relationship between power generated by the engine and battery power in HV Driving Mode. In HV Driving Mode, the battery is used as a buffer for power charge and discharge. Because the system is fitted with a

FIGURE 7 System operation at each vehicle speed and motor torque

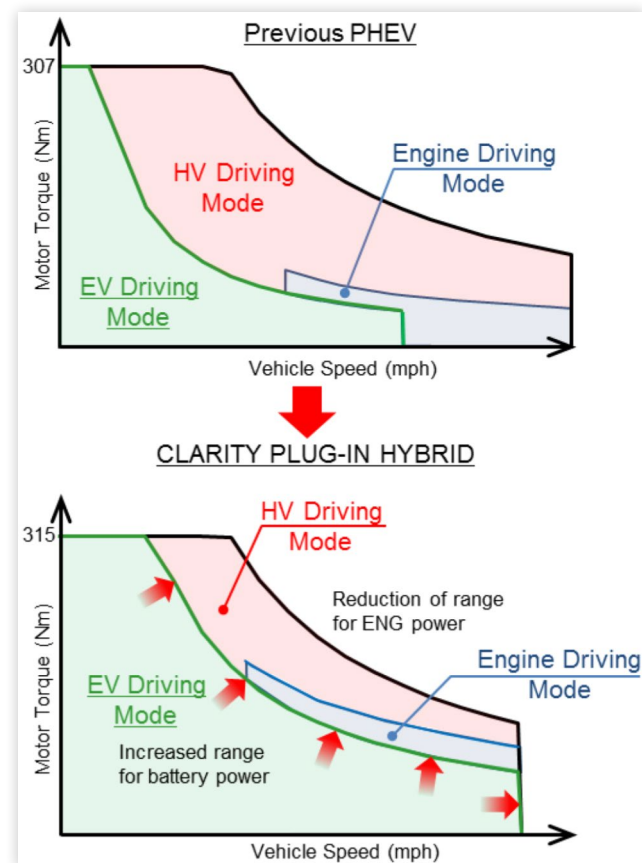
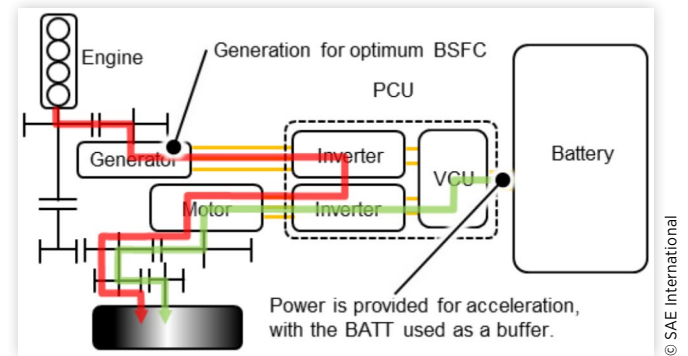

FIGURE 8 Relationship between power generated by the engine and battery power in HV Driving Mode



high-capacity battery, it is possible for the battery to supply power in response to changes in demand for power, thus controlling changes in the amount of power generated by the engine. The engine generates power while maintaining, to the extent possible, operation at the operating point for optimum brake specific fuel consumption (BSFC). The engine is able to maintain high-efficiency generation while controlling sudden changes in power output to the greatest extent possible.

During Engine Driving Mode, as shown in Figure 4, both engine power, via the direct connection to the clutch, and motor power are used. When the vehicle is cruising at high speeds, high-efficiency operation is made possible by the direct connection between the engine and the output shaft via the lock-up clutch.

Figure 9 shows an overview of drive power output in Engine Driving Mode. In order to realize the power necessary for acceleration in Engine Driving Mode in Honda's previous plug-in hybrid, it was necessary to disengage the lock-up clutch, boost engine power and increase the amount of power generated by the generator. Because power can be supplied by the high-power battery and high-power VCU in the developed powertrain, it is possible to accelerate using the motor to supplement drive power while maintaining the operating point for optimum engine BSFC, with the lock-up clutch engaged.

FIGURE 9 Overview of drive power output in Engine Driving Mode

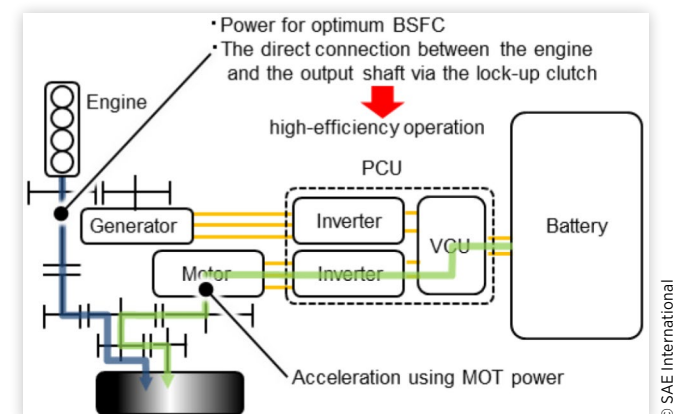

FIGURE 10 Frequency of engine speed at each vehicle speed during city and highway driving in CS operation

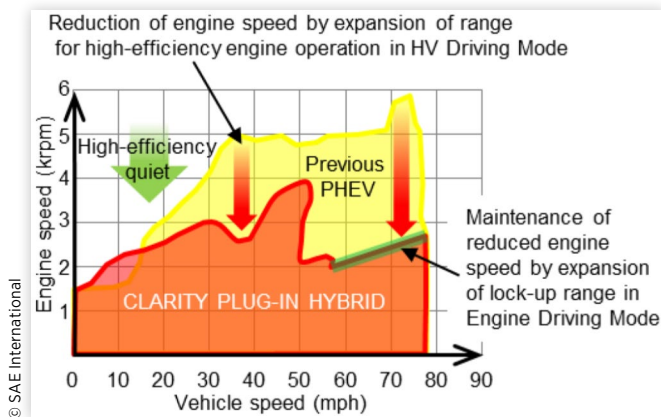

Figure 10 shows the frequency of engine speed at each vehicle speed during city and highway driving in CS operation. The frequency of high-efficiency engine drive in HV Driving Mode is increased in the developed powertrain, controlling fluctuations in engine speed. This makes it possible to realize quiet operation. In Engine Driving Mode, the range for maintenance of lock-up is increased, making it possible to control increases in engine speed in the high vehicle speed range. The realization of high engine efficiency and increased quietness with reduced engine speed has made it possible to downsize the engine from 2.0 to 1.5 liters.

Increased power in the battery and VCU has made it possible to realize operation in the high-efficiency range for the engine, helping to enable the vehicle to achieve a high 42 mpg level of fuel economy.

Overview of IPU and PCU

Overview of IPU

IPU Configuration Figure 11 shows the layout of the IPU. The IPU contains a 17 kWh lithium-ion battery, a 12 V DC-DC converter, and a battery ECU. And it is positioned under the floor of the vehicle.

FIGURE 11 IPU layout



TABLE 2 IPU specifications

Item	Unit	CLARITY PLUG-IN HYBRID	Previous PHEV
Capacity	kWh	17.0	6.7
Rated voltage	V	310.8	320
Cell (module)	-	168(14)	100
Cooling system	-	Coolant-cooled	Air-cooled
Vehicle position	-	Under-floor	Cabin

FIGURE 12 Battery power and CD operation energy

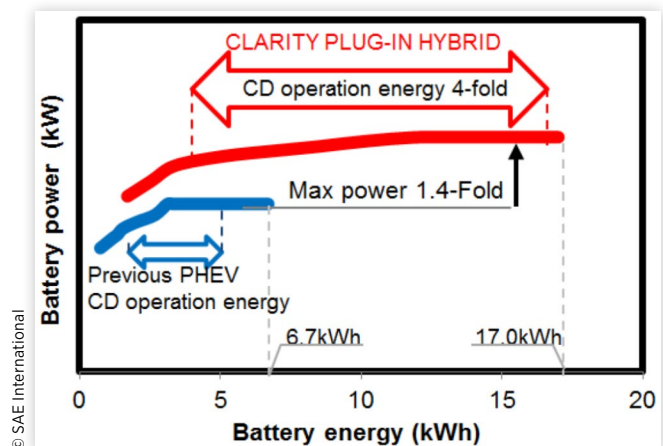

Figure 12 shows a comparison of the battery power and energy for Honda's previous PHEV and the CLARITY PLUG-IN HYBRID.

The energy of the battery employed in the CLARITY PLUG-IN HYBRID has been increased 2.5-fold and its power 1.4-fold against the battery employed in the previous PHEV, making it possible to realize a speed of 100 mph during EV operation. In addition, the SOC use range has been expanded, and energy in the charge-depleting (CD) operation range has been increased 4-fold.

IPU Technologies Figure 13 shows the parts layout in the IPU. The battery module is divided into two, situated front and rear, and the rear module is fitted in two levels.

FIGURE 13 Layout of IPU components

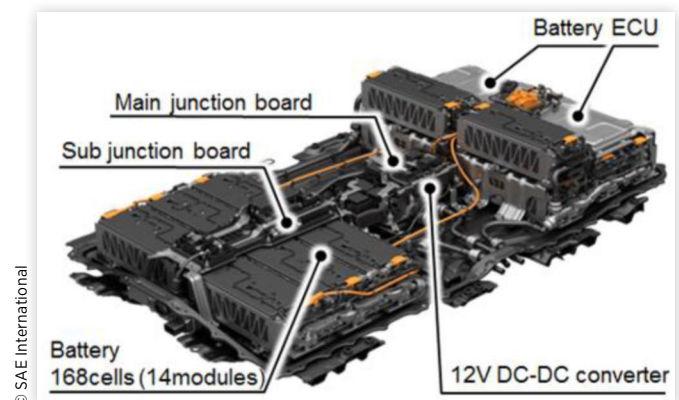
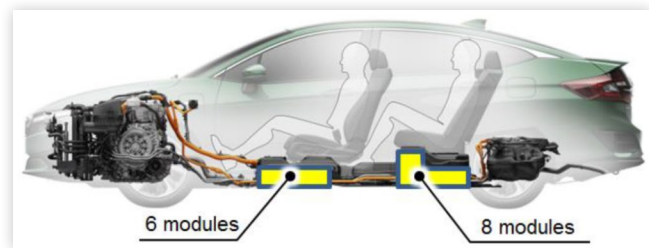

FIGURE 14 Powertrain side view of the CLARITY PLUG-IN HYBRID

12 V DC-DC converter is positioned in the center of the IPU, between the battery modules.

Figure 14 shows the position of the IPU in the vehicle. In Honda's previous PHEV, the IPU was positioned in the trunk. CLARITY PLUG-IN HYBRID has increased the battery capacity of IPU by 2.5-fold, but realized a cabin and luggage space equivalent to gasoline cars due to the under-floor installation. Because it is necessary for the floor in a sedan package to offer adequate leg room in the front and rear seats and allow for rear seat trunk access, the battery modules were divided and positioned under the front and rear seats.

Figure 15 shows the layout of the high-voltage wiring and components in the IPU. The high-voltage wiring and communications wiring is concentrated in the center of the IPU between the battery modules, allowing for an integrated configuration.

Battery Table 3 and Fig.16 show the specifications and size of the battery cells.

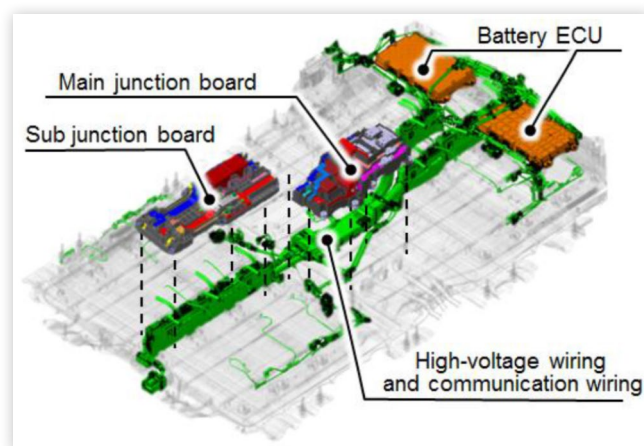
FIGURE 15 Layout of high-voltage wiring and components in IPU**TABLE 3** Cell specifications

Item	Unit	CLARITY PLUG-IN HYBRID	Previous PHEV
Type	-	Li-ion	Li-ion
Capacity	Ah	27.3	20.8
Rated voltage	V	3.7	3.2

FIGURE 16 Cell size**FIGURE 17** Specific power and specific energy of the cell

Figure 17 shows the evolution in the performance of the battery cells. The goal for the battery employed in the CLARITY PLUG-IN HYBRID was to extend AER against the previous PHEV, and as a result the battery's specific power was increased 1.4-fold and its specific energy 2.1-fold.

IPU Heat Management

Cooling System. Table 4 and Figure 18 show battery cooling performance and IPU size of the FIT EV and the CLARITY PLUG-IN HYBRID. The configuration of the under-floor IPU in the CLARITY PLUG-IN HYBRID was developed based on the unit employed in the FIT EV. The cooling system was selected taking into consideration the amount of heat generated by the battery and the volume of the cooling system itself. The FIT EV employed a configuration in which the bottoms of the cells were air-cooled. In the

TABLE 4 Battery cooling performance

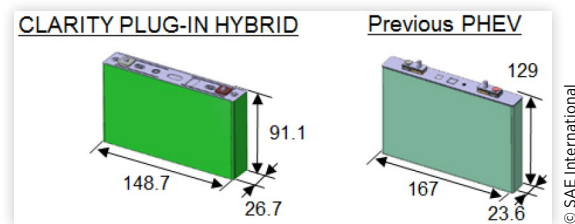
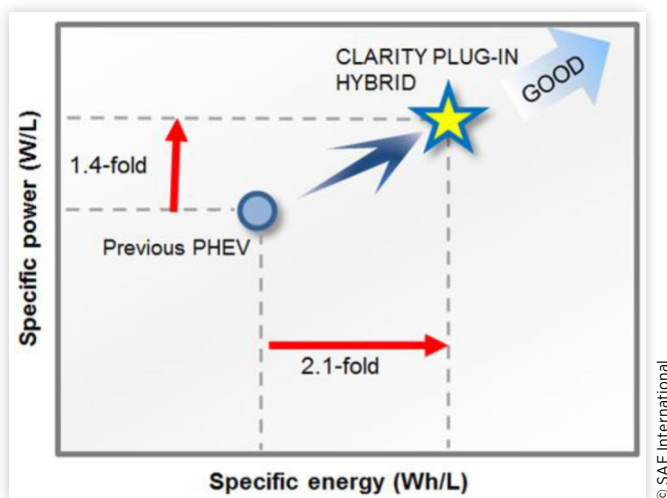
Item	Unit	CLARITY PLUG-IN HYBRID	FIT EV
Dimensions	mm	1787 / 1076 / 315	2112 / 1146 / 376
Battery energy	kWh	17.0	20.0
Number of cells	-	168	432
Cooling system	-	Coolant-cooled	Air-cooled
Cooling performance	W/(12 K)	665	190

FIGURE 18 IPU size

CLARITY PLUG-IN HYBRID, the amount of heat generated by each cell is higher. When using the air cooling system, it was found that the temperature of the battery rises, and when a high-temperature environment is realized, or high load-running is performed, power performance decreases. A system was therefore adopted in which the bottoms of the cells are coolant-cooled, realizing 3.5 times higher cooling performance than the air cooling.

Figure 19 shows changes in battery temperature in a high-temperature environment. The adoption of the coolant-cooling system has helped to ensure that it is unnecessary to limit the vehicle's driving performance due to high battery temperatures, even during high-load operation in a high-temperature environment.

Cooling System Configuration. Figure 20 shows the IPU cooling circuit. The components cooled by the system are the battery, the 12 V DC-DC converter, and the onboard charger. The system uses both an electric water pump (EWP) and a radiator (RAD) dedicated exclusively to the IPU, positioned at the front of the vehicle. After the battery (which has a low management temperature) is cooled by the circulation of Long-life-coolant (LLC) by the EWP, the 12 V DC-DC converter and the onboard charger are cooled. Because each component has a different management water temperature

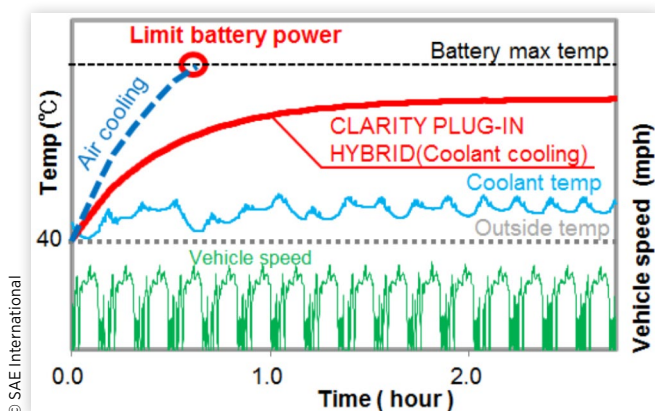
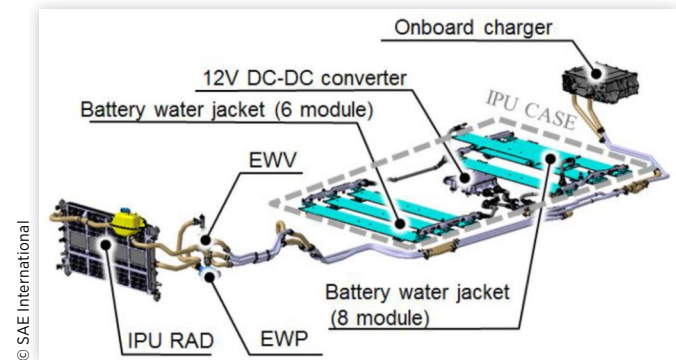
FIGURE 19 Battery temperature during high-load operation**FIGURE 20** Components of IPU cooling circuit

and the operating states in which each component produces heat differ, Electric water valve (EWV) and a bypass circuit have been employed to isolate the battery from the cooling circuit.

Table 5 shows vehicle operating states and the heat generation of each component. The battery is the main source of heat generation during vehicle operation, but when the vehicle is being charged, onboard charger is the main source of heat generation. If all the components were cooled using the same coolant channel, the heat generated by the charger during charging would cause the battery temperature to increase, resulting in the degradation of the battery. To help prevent this, the developed system employs a bypass water channel and a EWV that switches coolant circuits when the temperature of the coolant is higher than the temperature of the battery.

Figure 21 shows the IPU cooling channel during vehicle operation (the main circuit). Because the battery and the 12 V DC-DC converter generate heat during vehicle operation, coolant is circulated through the battery (BATT), the 12 V DC-DC converter (DCDC), and charger (CHG).

Figure 22 shows the IPU cooling channel (the bypass circuit) when the battery is being charged. During charging, a high level of heat is generated by the onboard charger, increasing the temperature of the coolant. Increases in battery

TABLE 5 Vehicle operating state and heat generation

Operation state	Battery	12 V DC-DC converter	Onboard charger
High-load CS operation	400 W	150 W	0 W
6.6 kW charge	30 W	80 W	750 W

FIGURE 21 IPU cooling channel during vehicle operation (Main)

FIGURE 22 IPU cooling channel during charging (Bypass)

temperature are therefore avoided by sending the coolant through the bypass circuit when the coolant temperature is higher than the battery temperature.

Figure 23 shows the effect of switching coolant channels via the EWV on battery temperature. The use of bypass channel has reduced frequency of high temperature during charging.

Figure 24 shows the effect in increasing battery durability. The durability of the battery increases 1.15-fold by using the bypass channel.

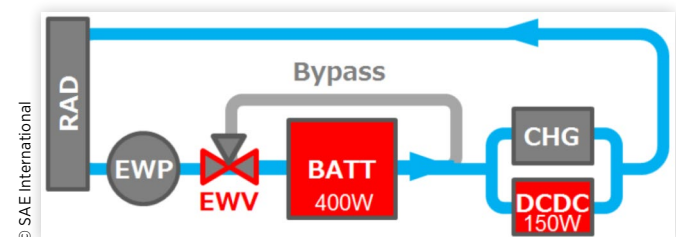
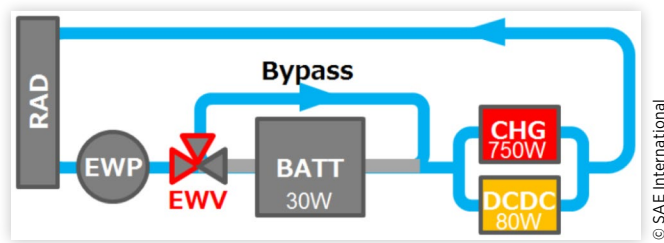
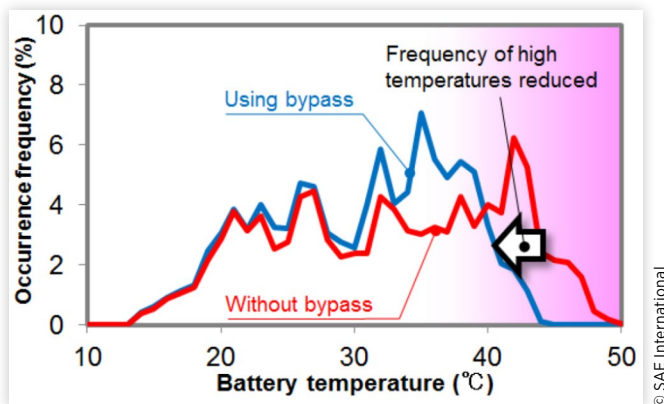
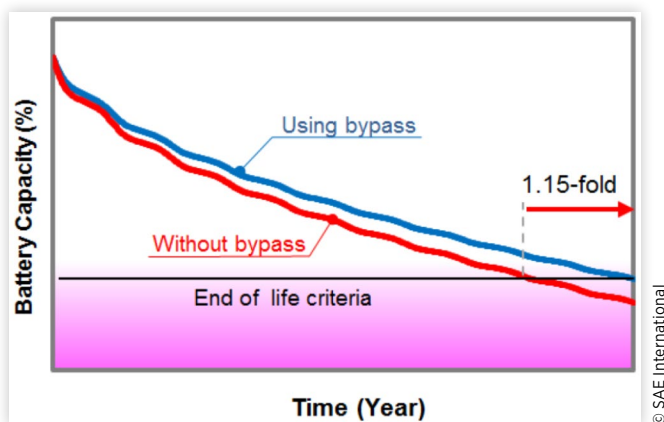
FIGURE 23 Bypass effect on frequency of battery temperature**FIGURE 24** Bypass effect on deterioration of battery capacity

Overview of PCU

The PCU integrates an inverter that drives the traction motor, an inverter that drives the generator, and a Voltage Control Unit (VCU), which is a battery voltage boost converter.

Figure 25 shows the configuration of the power-plant. The PCU is positioned above the transmission, and is directly connected to it. This configuration has realized a level of compactness in the power-plant, including the PCU, that makes it possible to fit the power-plant in the front engine room.

Figure 26 shows the configuration of the PCU. The Power Module is cooled by means of an integrated water jacket. The water jacket makes contact with the middle case containing the inductor. Coolant cooling of the inductor has made it possible to increase continuous power output.

FIGURE 25 Overview of power-plant**FIGURE 26** PCU configuration

TABLE 6 PCU specifications

Model		CLARITY PLUG-IN HYBRID	Previous PHEV
PCU	Maximum output (Motor inverter)	360kVA	400kVA
	Maximum voltage	650 V	700 V
	Weight	17.7 kg	17.4 kg
	Volume	11.7 L	11.5 L
	VCU maximum output	(1.3-fold) kW (In comparison with previous PHEV)	-
	VCU continuous power	(3.3-fold) kW (In comparison with previous PHEV)	-

Table 6 shows the specifications of the PCU.

In order to expand the EV Driving Mode shown in Figure 7, it was necessary to increase the power of the VCU that boosts battery voltage. An interleaved circuit configuration was employed to increase the power of the VCU, making it possible to increase the maximum power of the VCU 1.3-fold and its continuous power output 3.3-fold against the VCU employed in the previous PHEV. As a result, the vehicle realizes a speed of 100 mph during EV operation.

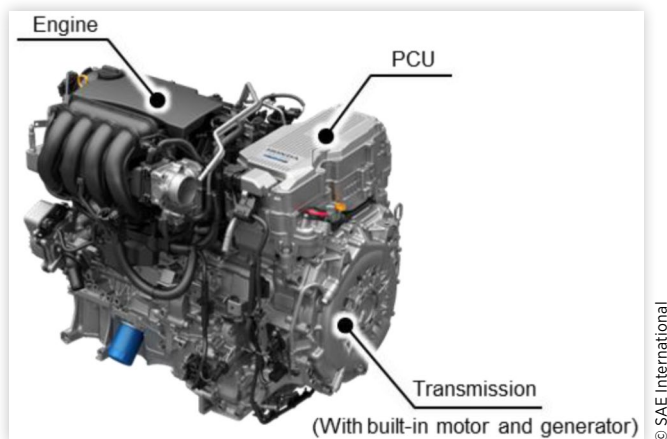
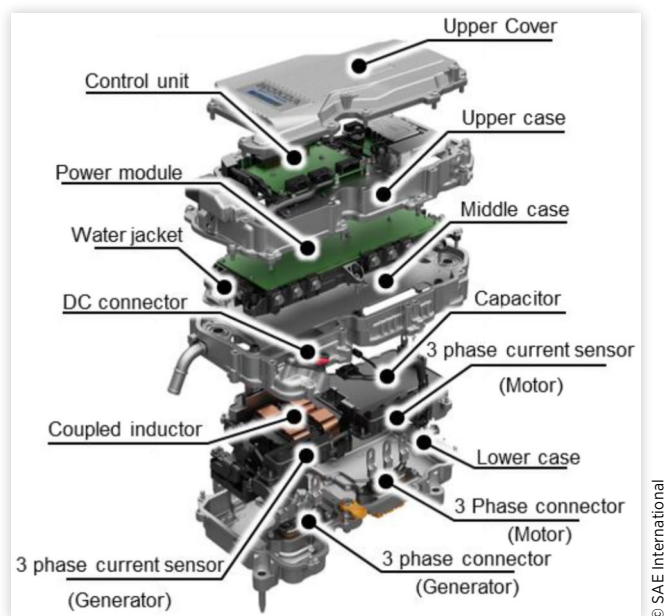
An increase in the volume of the PCU as a result of the increased power of the VCU would have made it challenging to fit the PCU in the engine room. The employment of a coupled inductor in the VCU made it possible to reduce the size of the inductor, allowing the unit to be positioned in the engine room.

Figures 27, 28, and 29 show the PCU circuit diagram, the VCU switching waveform, and the configuration of the coupled inductor, respectively. The two-phase coupled inductor has Phase 1 paired with Phase 2. For each phase, two coils are wound on a single core and current is run through them so that the magnetic fluxes generated in the core by the direct current are in reverse directions, thereby reducing the direct current magnetic flux (Figure 29). In addition, the timing for switching the phases coupled with each other is offset by 180° so that the alternating current component is also reduced. The effect of the former is to make the inductor

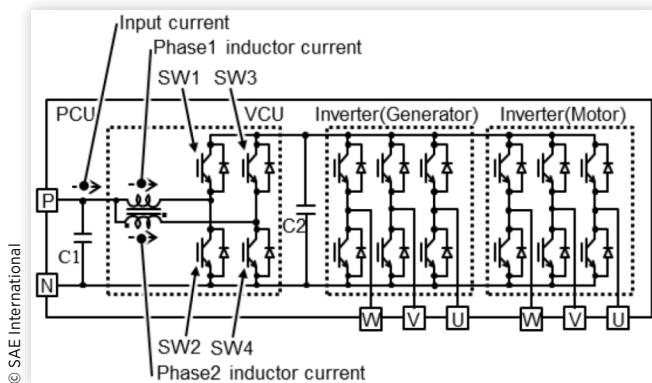
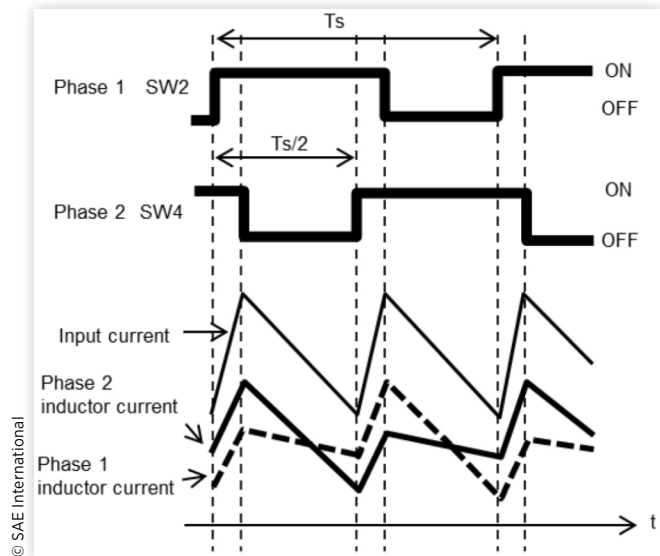
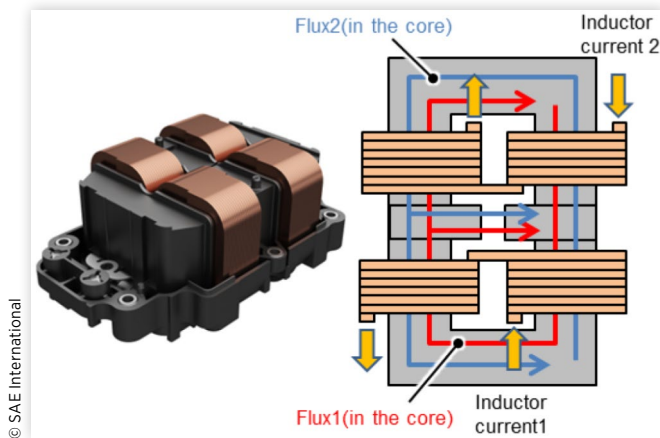
FIGURE 27 PCU circuit diagram**FIGURE 28** VCU switching waveform**FIGURE 29** Coupled inductor configuration

more compact, and that of the latter is for the ripple currents

FIGURE 30 Comparison of VCU power density

FIGURE 31 Power-plant layout in engine room

in the inductor to cancel each other out, enabling the smoothing capacitor to be made more compact.

Figure 30 compares the power density of the developed and previous VCU. Figure 31 shows the layout of the power-plant in the engine room. As Figure 30 shows, the power density of the developed VCU is 2.8-fold that of the previous VCU. As Figure 30 shows, the increased power density of the VCU has made it possible to control any increase in the front-rear length of the PCU, allowing the positioning of the unit in the engine room.

Conclusions

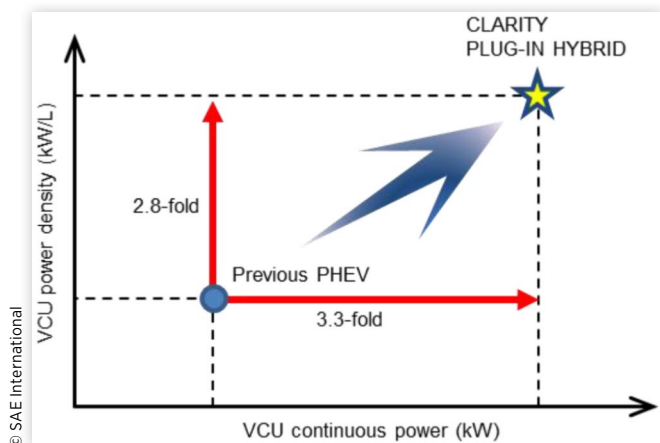
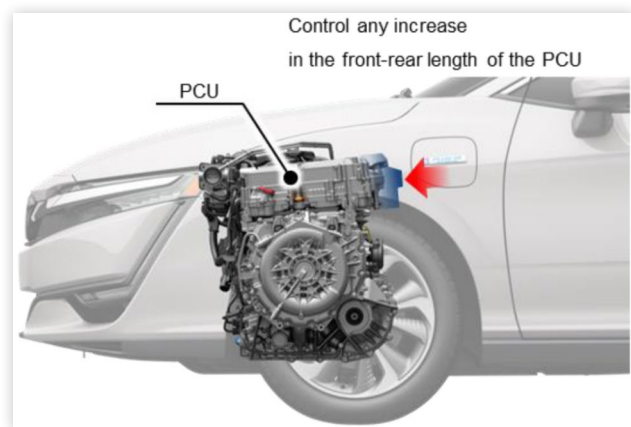
A powertrain has been developed for the 2017 model CLARITY PLUG-IN HYBRID, as follows:

- The capacity of the IPU battery has been increased 2.5-fold against Honda's previous PHEV, increasing power by 1.4-fold and making it possible to realize a speed of 100 mph during EV operation. The range of use of the SOC has been increased, increasing energy approximately 4-fold during CD operation. As a result, the vehicle realizes an AER of 47 miles. The positioning of the IPU under the floor of the vehicle has made it possible to realize cabin space for five passengers and a spacious trunk.
- The use of an interleaved circuit configuration in the VCU has increased the maximum power of the unit 1.3-fold and its continuous power output 3.3-fold against the VCU employed in the previous PHEV, making it possible to realize a speed of 100 mph during EV operation. The employment of a coupled inductor has increased the power density of the VCU 2.8-fold, making it possible to reduce the size of the unit and position it in the engine room.
- Increased power in the battery and VCU has made it possible to realize operation in the high-efficiency range for the engine, helping to enable the vehicle to achieve a high 42 mpg level of fuel economy. It has been possible to downsize the engine from 2.0 to 1.5 liters while realizing the necessary power and quiet operation.

References

1. Kazuhiro Saito, Hiroshi Otsuka, "Development of PCU for a New HEV Drive," JSAE Technical Paper No. 46-13, 13-16, 20135063, 2013.
2. Kitamoto, R., Sato, S., Nakamura, H., and Amano, A., "Development of Fuel Cell Boost Converter Using Coupled-Inductor for New FCV," SAE Technical Paper 2017-01-1224, 2017, doi:10.4271/2017-01-1224.