

Coolant Replacement and Check

Special Tool Required

Image	Description/Tool Number
A black, wheeled diagnostic station with a digital display and various cables attached. It has a handle on top and a carrying case on the back.	Honda GR8 Battery Diagnostic Station with AST Module (12 Volt) MTRGR811ASTH*

*Available through the Honda Tool and Equipment Program 888-424-6857

Replacement

NOTE:

- [How to read the torque specifications.](#)
- Running the electric motor control module coolant pump (for the ES or DT) without coolant may cause damage to the pump. The pump may be activated when the vehicle is turned to the ON mode.
- The DT coolant is also referred to as the inverter coolant because it cools heat generated by the inverter which is built in the PCU.
- Do not spill coolant on electrical parts and painted surfaces. If coolant gets on them, wipe it off immediately.

ES cooling system

1. Rear Seat Cushion - Remove

2. ES Expansion Tank Cap - Remove

1. Wait until the ES coolant is cool, then carefully remove the ES expansion tank cap.

3. Front Floor Undercover - Remove

4. ES Coolant - Drain

1. Disconnect the coolant hoses (A).

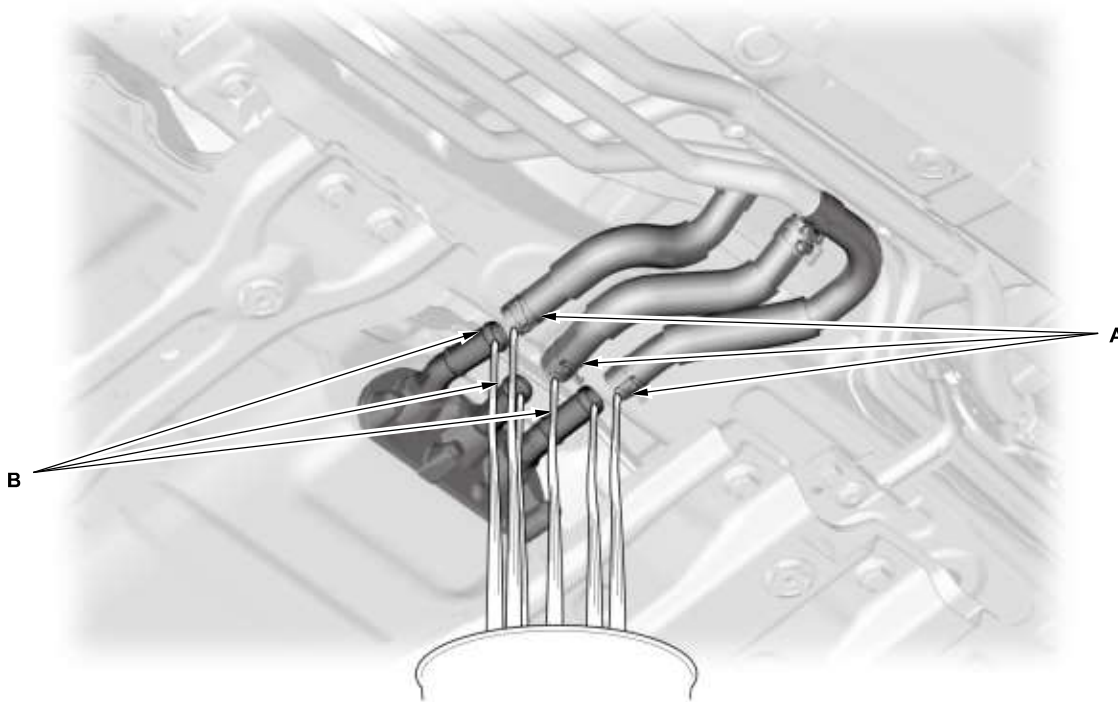

2. To remove the coolant inside the IPU, blow compressed air into the 3 pipes of the IPU, one at a time.

NOTE: After removing the coolant, plug the pipes and hoses.

5. ES Coolant - Refill

1. Follow the chart and pour the recommended coolant in the following procedure.

NOTE:

- Use Honda Long Life Antifreeze/Coolant Type 2, and if necessary add Honda Extreme Cold Weather Antifreeze/Coolant Type 2 (concentrate). Using a non-Honda coolant can result in corrosion, causing the cooling system to malfunction or fail.
- Honda Long Life Antifreeze/Coolant Type 2 is a mixture of 50 % antifreeze and 50 % water. Honda Extreme Cold Weather Antifreeze/Coolant Type 2 is a 100 % concentration coolant. Do not add water to either coolant.
- If the vehicle is regularly driven in very low temperatures (below -22 °F (-30 °C)), a 60 % concentration of coolant should be used.

Operation	Vehicle Usage (Desired Mixture)	Current Mixture	Coolant Drain	Add Amount of Honda Extreme Cold Weather Antifreeze/Coolant Type 2 (100 % concentrate)	Then add Honda Long Life Antifreeze/Coolant Type 2 (50/50)
Disassembly	Normal Area (50/50)	-	-	None	Top off the ES cooling system
	Very Cold Area (60/40)	-	-	About 1.3 L (44 fl oz)	
Coolant Winterizing	Very Cold Area (60/40)	-	-	About 1.3 L (44 fl oz)	

ES Coolant Refill Capacities (Including the DT expansion tank capacity of 0.64 L (0.169 US gal))
At Disassembly: 6.38 L (1.685 US gal)

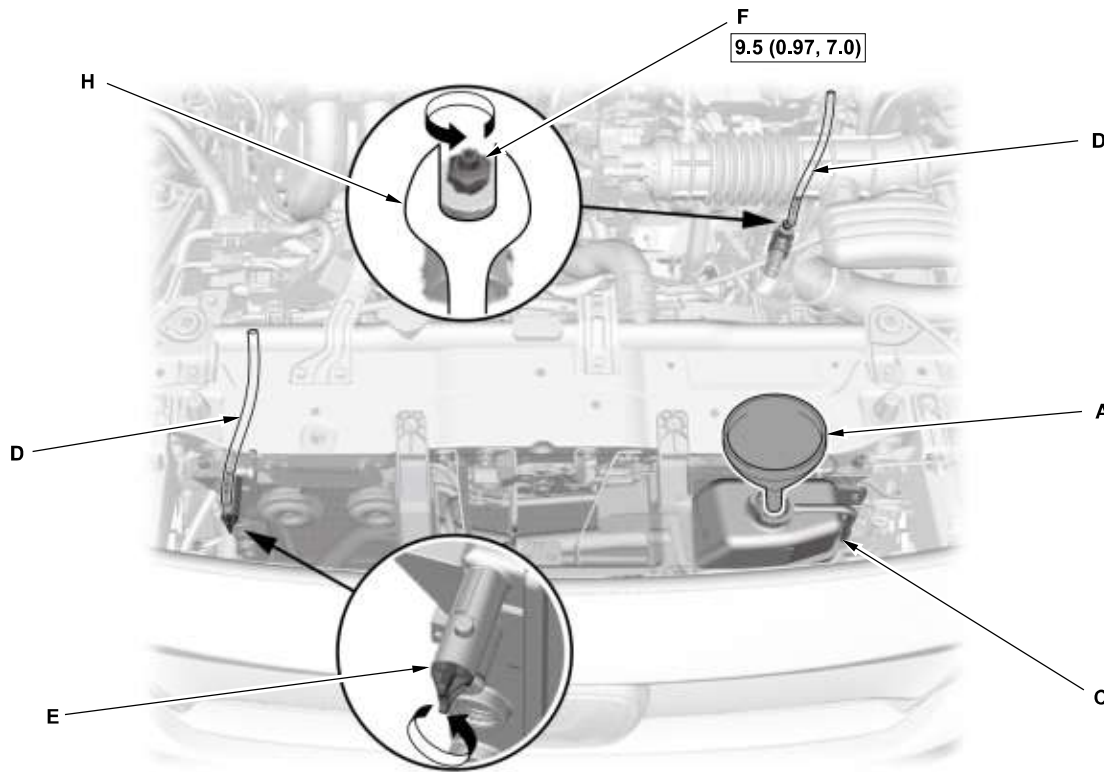

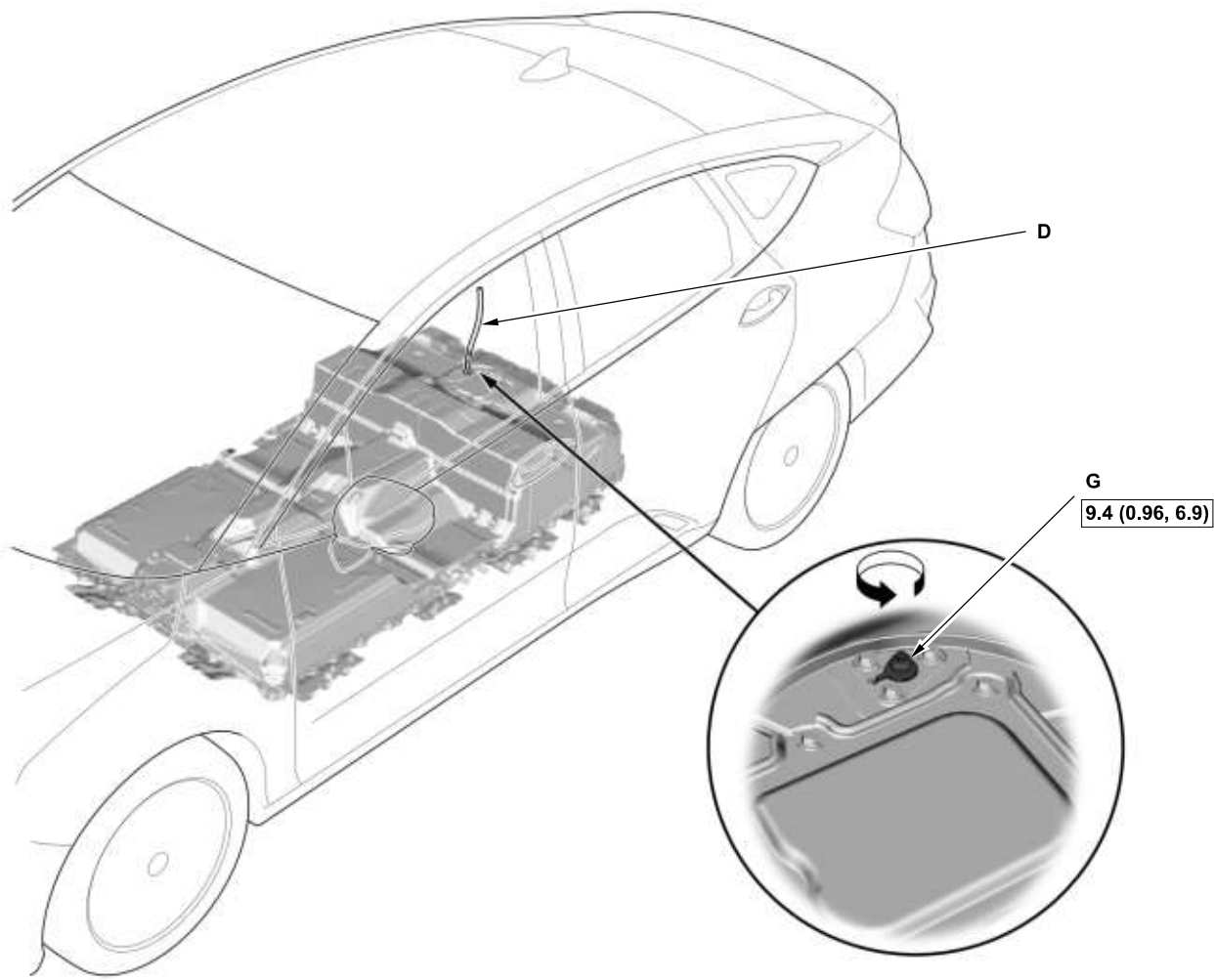

2. Install a coolant fill funnel (A) to the ES expansion tank (C).

3. Pour Honda Long Life Antifreeze/Coolant Type 2 until the coolant fill funnel is filled.

NOTE: Pour coolant into the fill funnel as necessary during the bleeding process.

4. Attach one end of each clear rubber hose (D) (3 required, commercially available) to the radiator breather plug (E), water valve breather bolt (F) and IPU breather bolt (G), individually.

5. Loosen the radiator breather plug.

6. While holding the water valve cooling pipe B with a wrench (H), loosen the water valve breather bolt.

7. Loosen the IPU breather bolt.

8. Wait until the bubbles stop coming out from the clear rubber hoses, then tighten the breather plug and bolts.

NOTE: It is normal if there are no bubbles present.

6. ES Coolant - Air Bleed

1. Connect the Honda GR8 battery diagnostic station and set it to the power supply mode.
2. [Connect the HDS.](#)
3. Turn the vehicle to the ON mode.
4. Select ELECTRIC POWERTRAIN system.
5. Select ADJUSTMENT, then ES COOLANT AIR BLEEDING and select ENTER to start the air bleeding.

NOTE:

- Do not run the ES electric water pump without coolant in the cooling system.
 - Do not loosen the breather bolt and the breather plug, when running the ES electric water pump.
 - Once the air bleeding is started, the three-way valve status will start from the battery side and switched to the bypass side automatically after about 5 minutes.
 - This function cannot be executed when the ES coolant temperature is 70 degrees or higher.
 - Watch the electric water pump speed during the procedure. If you do not see the speed fluctuate or hear a operating noise from the ES electric water pump, exit the function and start over. It may be necessary to force-down the i-HDS in some cases.
6. Run the air bleeding for 10 minutes, then press the Exit button.
 7. Turn the vehicle to the OFF (LOCK) mode. Loosen the IPU breather bolt, and wait until the bubbles stop coming out of the clear rubber hose.
 8. Tighten the IPU breather bolt.
 9. Turn the vehicle to the ON mode.
 10. Do the ES Coolant Air Bleeding again.
 11. Run the air bleeding for 10 minutes, then stop it.
 12. Turn the vehicle to the OFF (LOCK) mode. Loosen the radiator breather plug, and wait until the bubbles stop coming out of the clear rubber hose.
 13. Tighten the breather plug.
 14. Loosen the water valve breather bolt, and wait until the bubbles stop coming out of the clear rubber hose.

NOTE: It is normal if there are no bubbles present.

15. Tighten the water valve breather bolt.
16. Remove the coolant fill funnel and the clear rubber hoses.
17. Check the coolant level in the ES expansion tank.

7. All Removed Parts - Install

1. Install the parts in the reverse order of removal.

DT cooling system

1. DT Expansion Tank Cap - Remove

1. Wait until the DT coolant is cool, then carefully remove the DT expansion tank cap.

2. Front Motor Undercover - Remove

3. DT Coolant - Drain

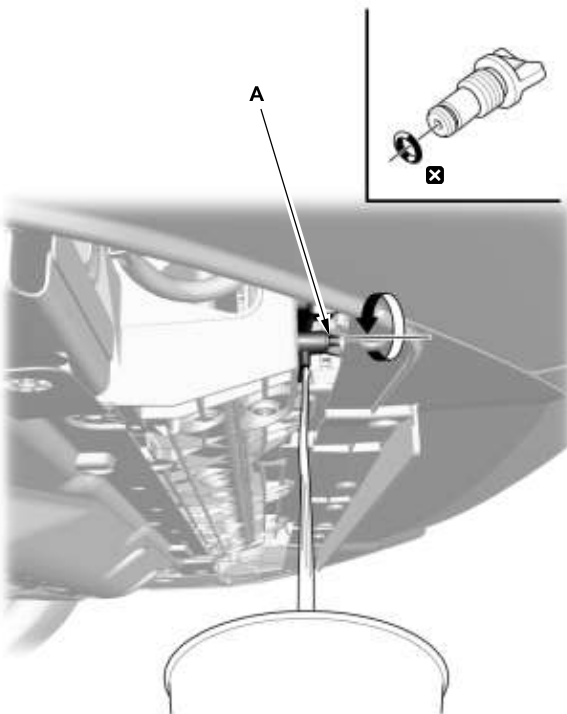

1. Loosen the DT coolant drain plug (A), and drain the coolant.
2. After the coolant has drained, tighten the DT drain plug with a new O-ring.

4. DT Coolant - Refill

1. Follow the chart and pour the recommended coolant in the following procedure.

NOTE:

- Use Honda Long Life Antifreeze/Coolant Type 2, and if necessary add Honda Extreme Cold Weather Antifreeze/Coolant Type 2 (concentrate). Using a non-Honda coolant can result in corrosion, causing the cooling system to malfunction or fail.
- Honda Long Life Antifreeze/Coolant Type 2 is a mixture of 50 % antifreeze and 50 % water. Honda Extreme Cold Weather Antifreeze/Coolant Type 2 is a 100 % concentration coolant. Do not add water to either coolant.
- If the vehicle is regularly driven in very low temperatures (below -22 °F (-30 °C)), a 60 % concentration of coolant should be used.

Operation	Vehicle Usage (Desired Mixture)	Current Mixture	Coolant Drain	Add Amount of Honda Extreme Cold Weather Antifreeze/Coolant Type 2 (100 % concentrate)	Then add Honda Long Life Antifreeze/Coolant Type 2 (50/50)
Coolant Change	Normal Area (50/50)	50/50 60/40 unknown	Drain DT radiator and DT expansion tank	None	Top off the DT cooling system
	Very Cold Area (60/40)	50/50 unknown	Drain DT radiator and DT expansion tank	About 0.3 L (11 fl oz)	
		60/40		About 0.3 L (11 fl oz)	
Disassembly	Normal Area (50/50)	-	-	None	
	Very Cold Area (60/40)	-	-	About 0.3 L (11 fl oz)	
Coolant Winterizing	Very Cold Area (60/40)	50/50	Drain about 0.3 L(11 fl oz) from DT radiator	About 0.3 L (11 fl oz)	
		unknown*	Drain DT radiator and DT expansion tank		

*: When you want to winterize the coolant with the minimum amount of coolant change but the current coolant concentration in the vehicle is unknown, you must drain all coolant from the DT cooling system.

DT Coolant Refill Capacities (Including the DT expansion tank capacity of 0.21 L (0.055 US gal))

At Coolant Change: 1.03 L (0.272 US gal)

At Disassembly: 1.21 L (0.320 US gal)

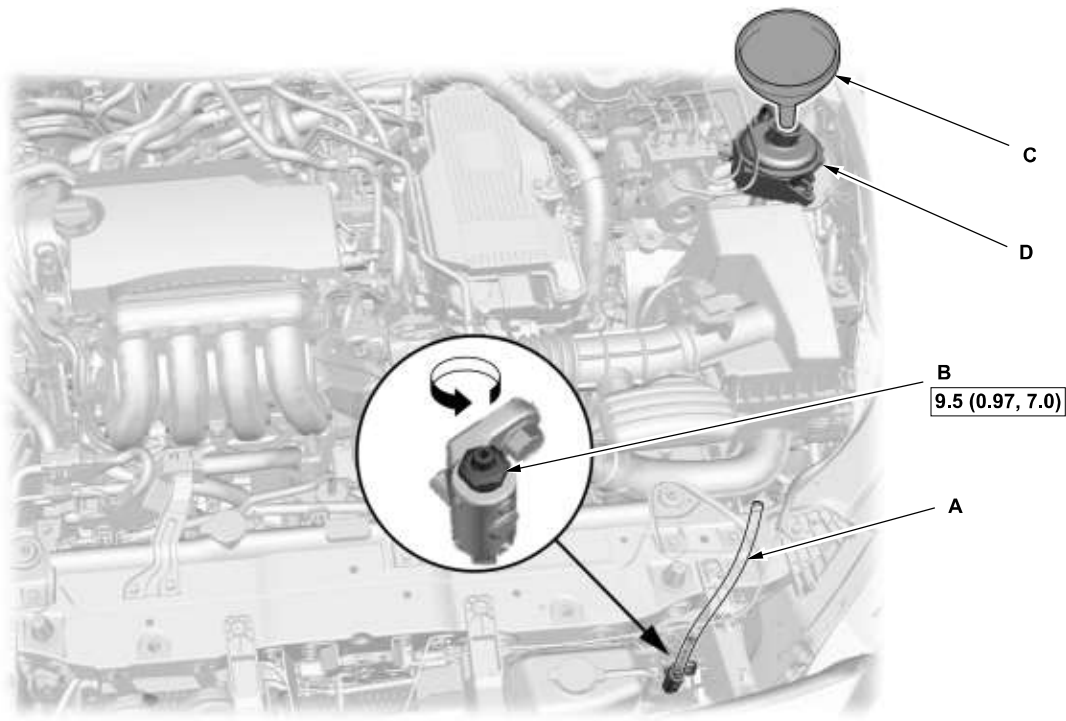

2. Attach one end of a clear rubber hose (A) (commercially available) to the breather bolt (B).
3. Loosen the breather bolt (B).
4. Install a coolant fill funnel (C) to the DT expansion tank(D).
5. Pour Honda Long Life Antifreeze/Coolant Type 2 until the coolant fill funnel is filled.

NOTE: Pour coolant into the fill funnel as necessary during the bleeding process.

6. Wait until the bubbles stop coming out from the clear rubber hoses, then tighten the breather bolt.

5. DT Coolant - Air Bleed

1. Connect the Honda GR8 battery diagnostic station and set it to the power supply mode.
2. [Connect the HDS.](#)
3. Turn the vehicle to the ON mode.
4. Select ELECTRIC POWERTRAIN system.
5. Select ADJUSTMENT, then DT COOLANT AIR BLEEDING and select START to start the air bleeding.

NOTE:

- Do not run the DT electric water pump without coolant in the cooling system.
- Do not loosen the breather bolt, when running the DT electric water pump.
- Watch the electric water pump speed during the procedure. If you do not see the speed fluctuate or hear a operating noise from the water pump, exit the function and start over. It may be necessary to force-down the i-HDS in some cases.
- This function cannot be executed when the ES coolant temperature is 70 degrees or higher.

6. Run the air bleeding for 10 minutes, then press the Stop button.
7. Loosen the breather bolt. Exit the air bleeding and turn the vehicle to the OFF (LOCK) mode. Loosen the breather bolt and wait until the bubbles stop coming out of the clear rubber hose.
8. Tighten the breather bolt.
9. Remove the coolant fill funnel and the clear rubber hose.
10. Check the coolant level in the DT expansion tank.

6. All Removed Parts - Install

1. Install the parts in the reverse order of removal.

Check

ES coolant system

1. ES Coolant - Check

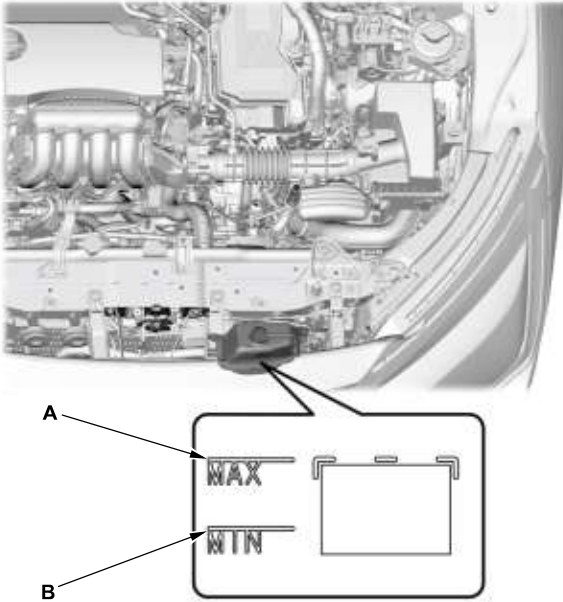

1. Check the coolant level in the ES expansion tank. Make sure it is between the MAX mark (A) and the MIN mark (B).
2. If the coolant level in the ES expansion tank is at or below the MIN mark, add the recommended coolant to bring it to the MAX mark, then [inspect the cooling system for leaks](#)

NOTE

- Always use Honda Long Life Antifreeze/Coolant Type 2. Using a non- Honda coolant can result in corrosion, causing the cooling system to malfunction or fail.
- Honda Long Life Antifreeze/Coolant Type 2 is a mixture of 50 % antifreeze and 50 % water. Do not add water.

DT cooling system

1. DT Coolant - Check

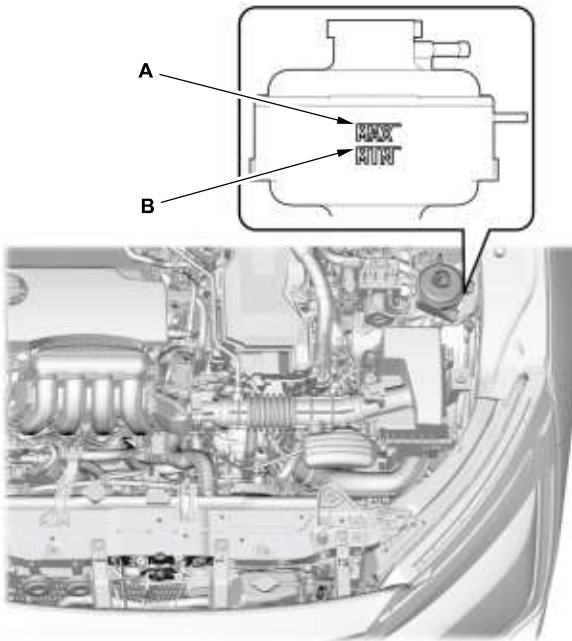

1. Check the coolant level in the DT expansion tank. Make sure it is between the MAX mark (A) and the MIN mark (B).
2. If the coolant level in the DT expansion tank is at or below the MIN mark, add the recommended coolant to bring it to the MAX mark, then [inspect the cooling system for leaks](#)

NOTE

- Always use Honda Long Life Antifreeze/Coolant Type 2. Using a non- Honda coolant can result in corrosion, causing the cooling system to malfunction or fail.
- Honda Long Life Antifreeze/Coolant Type 2 is a mixture of 50 % antifreeze and 50 % water. Do not add water.